



AWM.
AMAROO
POST LEG



POST LEG

The Post Leg Table by AWM Amaroo is a timeless design that combines minimalist aesthetics with exceptional practicality and customisation. Available in round, square and rectangular top profiles, the Post Leg workstation integrates seamlessly with our range of power and data solutions. Its versatile design is suitable for all your office needs, from meeting rooms to breakout areas.

PROUDLY AUSTRALIAN

At AWM Amaroo, our pride and passion drive our dedication to Australian manufacturing. From our design process to final production, we ensure that every product is crafted with 100% Aussie-born quality.

As a locally-based company, we are committed to delivering bespoke products that reflect the excellence of Australian craftsmanship.

SPECIFICATIONS

Warranty	10 Years
Lead Time	4 - 6 Weeks
Manufacture	Australia
Details	<p>Height*: 725mm Fixed Height</p> <p>Leg Profile: Standard Ø70 mm Round Profile</p> <p>Available in Black or White powder coat as standard</p> <p>Power and Data: Below-desk, In-Desk, and Above Desk</p>
Options	<p>Configurations: Round, Square, or Rectangle</p> <p>Finishes: Customisable Top and Edge Finishes</p> <p>Customisable Power Coat Frame</p>

Base Finishes



Black Powder Coat



White Powder Coat



Client Specified Powder Coat†



Client Specified

Top Finishes



STANDARD CONFIGURATIONS

Round Table

Dimensions	W	900 - 1500mm
	D	900 - 1500mm
	H	725mm

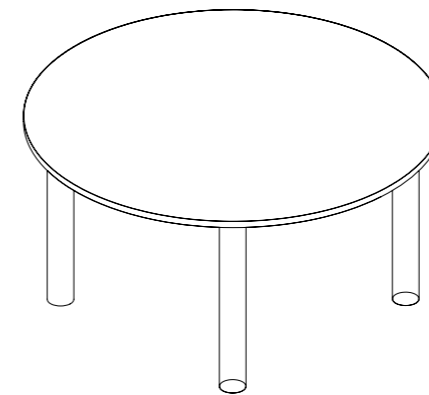

Square Table

Dimensions	W	600 - 1500mm
	D	600 - 1500mm
	H	725mm

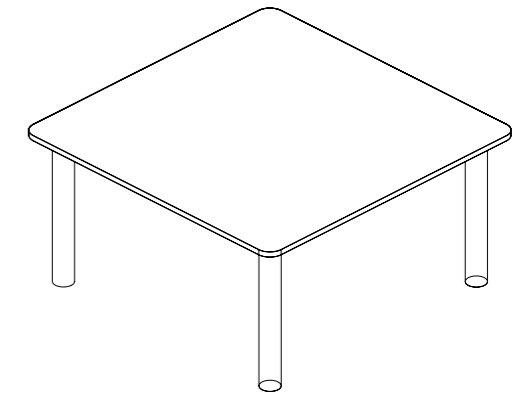

Rectangle Table

Dimensions	W	1600 - 5000mm
	D	600 - 1500mm
	H	725mm

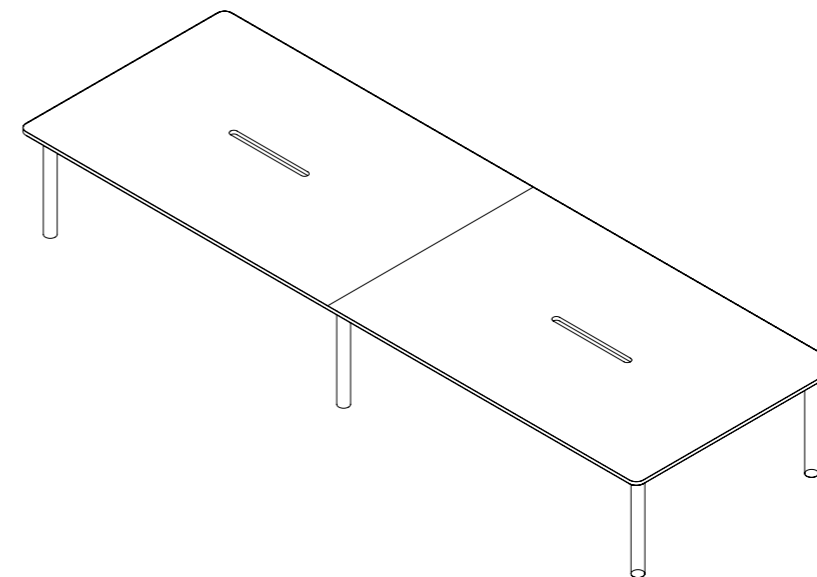

*Dimensions given are for each individual worktop. Heights include the thickness of a standard 25mm worktop.

†Client specified powder coat is available on indent.



[Product Type/Name]
[Project/Project Location]

AWM. AMAROO

AWM is committed to adopting processes and practices aimed at reducing our environmental footprint whilst maintaining a superior level of quality. As a result of our diligence and leadership within this area, AWM is certified for a number of quality and environmental accreditations that acknowledge our commitment to producing superior quality products with as minimal environmental impact as possible.



ISO 9001
Quality
Management



ISO 14001
Environmental
Management



ISO 45001
Health & Safety
Management

E. sales@awm.net.au
P. 1300 475 217

Sydney Showroom
118 Commonwealth St
Surry Hills, NSW 2010

Fairfield Factory
9 Malta St
Fairfield East, NSW 2165

Melbourne Showroom
132-134 Adderley St
West Melbourne, VIC 3003

A
.A



**AWM.
AMAROO**

Colour and swatches shown in this document are for reference only and may differ in actuality. Copyright AWM Amaroo. All concepts, photography and ideas contained within this document are private and confidential. They must not be reproduced in any way or form and remain the intellectual property of AWM. All products are registered designs with IP Australia.

AWM.NET.AU