



E2

MONITOR ARMS

**AWM.
AMAROO**



**HAT
COLLECTIVE™**
HUMAN ACTIVE TECHNOLOGY

SLEEK DESIGN. MAXIMUM FLEXIBILITY.

An evolution in ergonomics. Introducing “E2”, the next generation of the original Envoy monitor arm. E2 offers a polished design with maximum flexibility for user screen interaction. With a recent study citing 24% of workers experience neck pain, the E2 seeks to optimize user performance and adjustment control while eliminating the strain on neck muscles.





With a fast and easy install, quick release tilter and featured sliders on the dual arm, the E2 proves to be the ideal monitor arm for both home and office environments.

FEATURES

- **Sleek:** Clean lines and a modern silhouette provide a stylish profile for either home or office.
- **Ergonomic:** Allows monitors to be placed at an ergonomically correct distance from the user’s eyes to increase comfort and productivity no matter where a person is working.
- **Dynamic:** Portrait-to-landscape rotation feature reduces stress on the neck and shoulders.
- **Easy:** Tension indicator allows the user to pre-counterbalance arms based on monitor weight prior to installation.
- **Compatible:** VESA-monitor compatible – 75mm & 100mm VESA adapters included.

SPECIFICATIONS

Finishes

	Flat White 248
	Silver 124
	Vista Black 104

E2 Dual

Screen Size: Up to 27"
 Height Adjustment: 13"
 Max Monitor Height: 18.5"
 Width Adjustment Range: 17.5" – 28.5"
 Rotation: 180° or 360° at base
 Weight Capacity: 2.2 - 20 lbs. per monitor
 Mount: C-Clamp, Grommet
 Compatibility: Up to 1.5" desk thickness

E2 Single

Screen Size: Within weight range
 Height Adjustment: 13.3"
 Max Monitor Height: 20.6"
 Extension Range: 23.7"
 Rotation: 180° or 360° at base
 Weight Capacity:
 Flat Monitor: 2.2 - 20 lbs.
 Curved Monitor: Up to 16 lbs.
 Mount: C-Clamp, Grommet
 Compatibility: Up to 1.5" desk thickness

Part Numbers

E2-1-_-_-
 E2-2-_-_-

Mount Conversion Kits

8524-FM-CK: Flexmount Conversion Kit
 8524-TM-CK: Thru-Desk Conversion Kit, E2-1
 8540-TM-CK: Thru-Desk Conversion Kit, E2-2



Dual arm features sliders for maximum adjustability

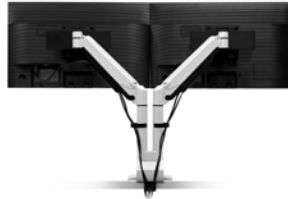

Cable management allows for a clutter-free workspace



Dual arm features tension indicator for easy installation

WARRANTY

10 Years

E2-1

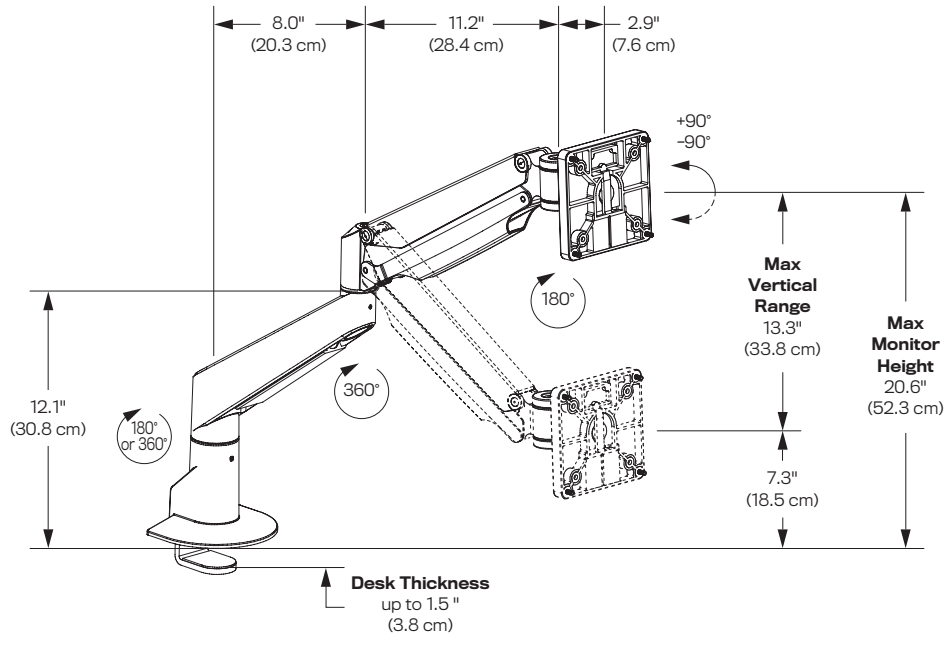

C-Clamp

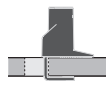

Grommet

E2-2

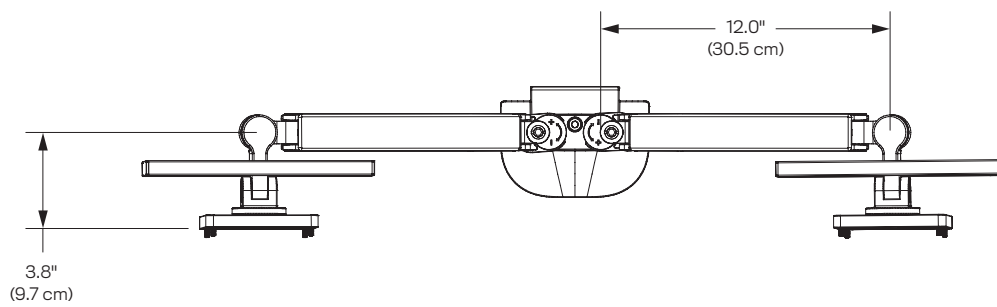
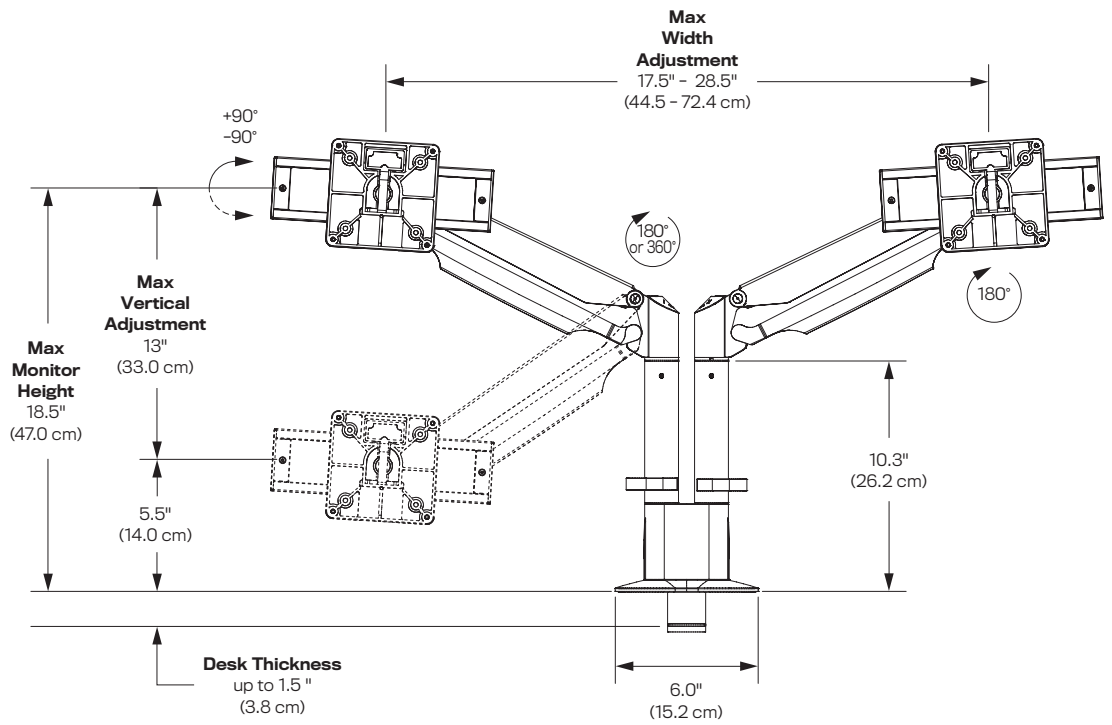

C-Clamp

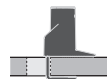

Grommet