

M/FLEX

monitor arm system

Humanscale®



AWM

**AWM
AMARO**

1300 475 217

awm.net.au

sales@awm.net.au

M/FLEX TRANSFORMS ANY WORKSPACE with unprecedented flexibility and ergonomic performance. Designed for today's agile work environment, users can easily add or remove monitors without disrupting the originally configured installation. This multi-monitor arm system accommodates endless configurations and is fully compatible with Humanscale's next generation monitor arms — providing all of the cutting-edge features of the line.

Easy to install and simple to upgrade for an overall reduced cost of ownership, M/Flex is the most scalable solution available for the modern workplace.



M/Flex's modular design makes it simple to reconfigure and allows for independent adjustment of monitors when they are used separately — encouraging flexibility and collaboration at the workstation.

Its revolutionary adjustable brackets, B1 and B12, allow the user to easily upgrade to multiple monitors without the need to purchase any additional equipment aside from the monitor arm itself. Simply remove the cover and pop the arm into place using Quick Release joints that instantly snap together for a secure fit.

Design Story

Humanscale Design Studio designed M/Flex to be easy to install, simple to upgrade and meet the needs of the ever-evolving workplace. Unlike other multi-monitor solutions, M/Flex has a small footprint and a sleek, minimal aesthetic that will stand the test of time in both performance and design.

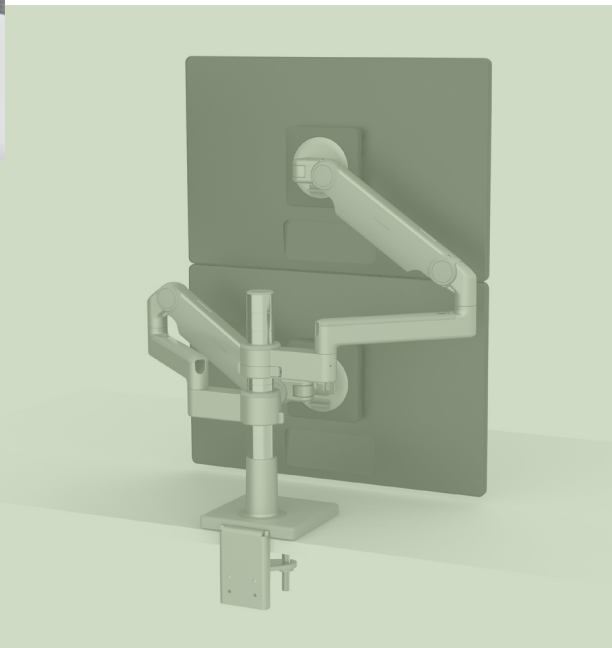

Features

- Scalable solution accommodates future additions of up to 6 monitors
- Compatible with Humanscale's M2.1, M8.1 and M10 monitor arms
- Reduces future installation costs by allowing for simple reconfigurations
- Available with accessories such as Notebook Holders, Crossbars, Thin Client Holders, UFEAs, Colored VESA Covers and Sliders
- Patent-pending Smart Stop allows the user to customize the rotation of the arm, preventing overhang and protecting surrounding equipment
- Patent-pending Quick Release Joints instantly snap together for a secure and robust fit, simplifying installation
- Compatible with M/Connect, M/Connect 2 and M/Power, the first-ever integrated monitor arm bases and docking stations of their kind

Specifications

Weight Capacity	Supports up to 100 lbs.
Maximum Arm Reach	Up to 28"
Maximum Height Adjustment	Up to 10" dynamic 30" static
Monitor Capacity	Up to 6 monitors
Color Options	Polished Aluminum with White Trim Silver with Gray Trim Black with Black Trim
Product Material	Recycled Aluminum
Warranty	15 years 24/7

Environmental Story

M/Flex is designed using fewer and lighter components to conserve energy, save valuable resources and reduce its environmental impact. Like all Humanscale products, M/Flex is built with sustainable, non-toxic material and its durable design ensures that it won't need to be replaced for many years.

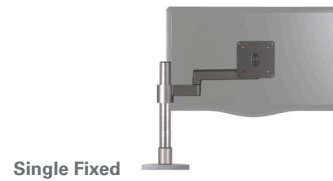

Single Fixed

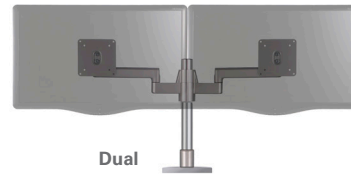

Dual

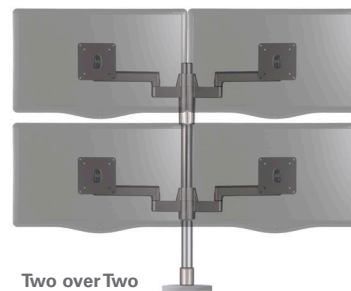

Two over Two

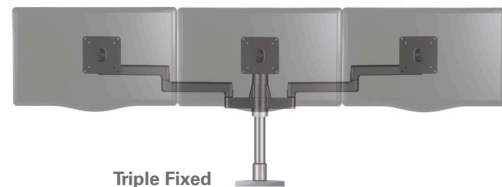

Triple Fixed

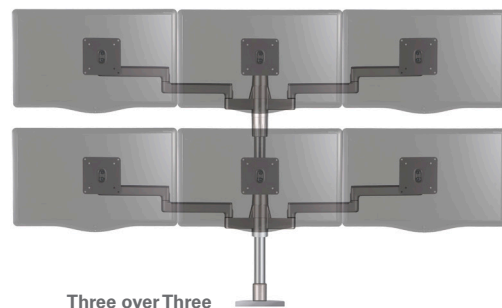

Three over Three