

# M10

Desk Mount  
Assembly Instructions

Humanscale®

# INSTALLATION HARDWARE

①

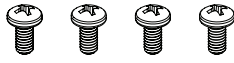

4 Standard VESA Bracket Screws

②



4 Plastic Spacers

③

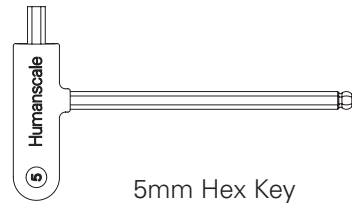

5mm Hex Key

④

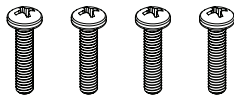

4 Extended VESA Bracket Screws

⑤

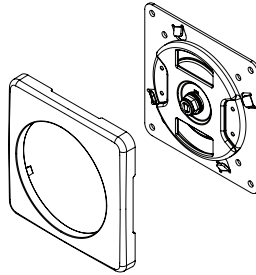

VESA Bracket and Cover

⑥

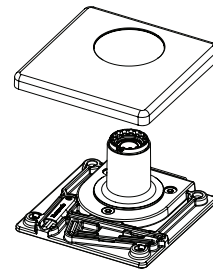

**NOTE:** 4mm and 5mm Hex Key can be found under the plastic base cover.

⑦



8 mm Hex Key

⑧

Bolt-Through Mount

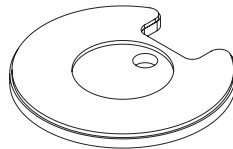

Bolt-Through Plate

⑨

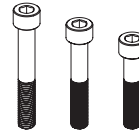

Bolt-Through Bolts

Sliding Desk Mount

⑩

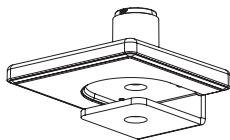

Clamp Mount

⑪

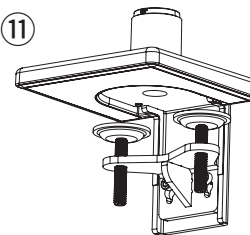

Crossbar Installation Hardware

⑫



4mm Hex Key

⑬

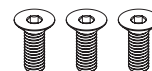

3 Crossbar Link Screws

# Assembly Instructions

## Attach Mount To Work Surface

### Clamp Mount

**NOTE:** There are two sets of Bracket Screw holes to accommodate the thickness of every work surface. Use the upper holes for surfaces up to 1.8" (48mm) thick and lower holes for surfaces up to 2.7" (68mm) thick.

#### A - For installation on open edge of work surface:

- 1 Slide Mount (A) against work surface edge and fully tighten Clamp screws(B) with 5mm hex key (C).

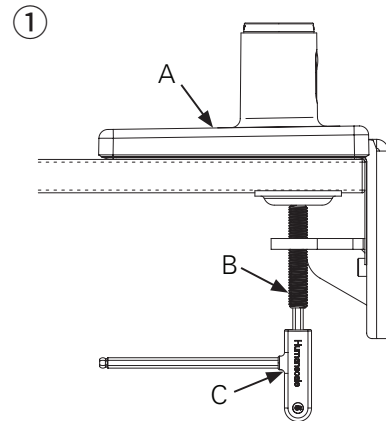

#### B - For installation on work surface positioned against a wall or panel:

**NOTE:** This method can also be used to mount through grommet holes wider than 3"

- 1 Detach the Bottom Clamp (D) from the Top Bracket (E) by loosening Bracket Screws (F) with 5mm hex key.
- 2 Position the Top Bracket against work surface edge.
- 3 Underneath the work surface, reattach the Bottom Clamp to the Top Bracket using the Bracket screws.
- 4 Fully tighten the Clamp Screws (G) with 5mm hex key.

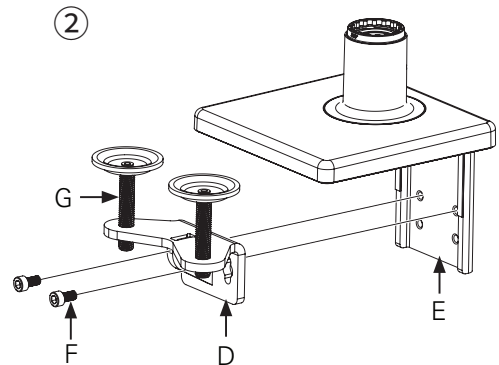

**NOTE:** Clamp Mounts cannot be used to mount the M10 to any vertical surface.

### Sliding Desk Mount

#### C - For installation on a desk with minimal clamp clearance:

- 1 Remove Base Cover.
- 2 Loosely attach Clamp Bracket (H) to base with three included screws (I). The screws should not be tightened all the way.
- 3 Slide the base and clamp over the back edge of the work surface until the clamp rests on the edge.
- 4 Fully tighten the three clamp screws to secure the base to the work surface.

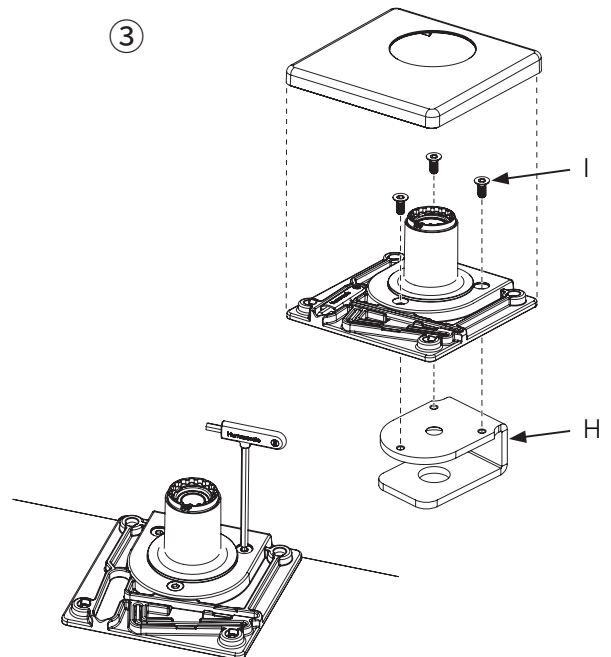

## BOLT-THROUGH MOUNT

### D - For installation on work surface with no access for clamp system:

- 1 Drill 1/2" hole through work surface in desired location.

**NOTE:** Bolt-Through Mount can accommodate a hole up to 4" (102mm) in diameter. If hole is 2" (51mm) or more, cables can be routed through the hole. For some 2" grommet holes, cables should be routed before installation of mount to accommodate cable plugs (cable access is approximately 1.5" x 0.25" with 2" grommets).

- 2 Position the M10 Base over the work surface hole (J).
- 3 Align Bolt-Through Plate, foam side up, under the work surface. Pass the Bolt (K) through the hole in the plate and screw into M8 base by using 8mm hex key (L).

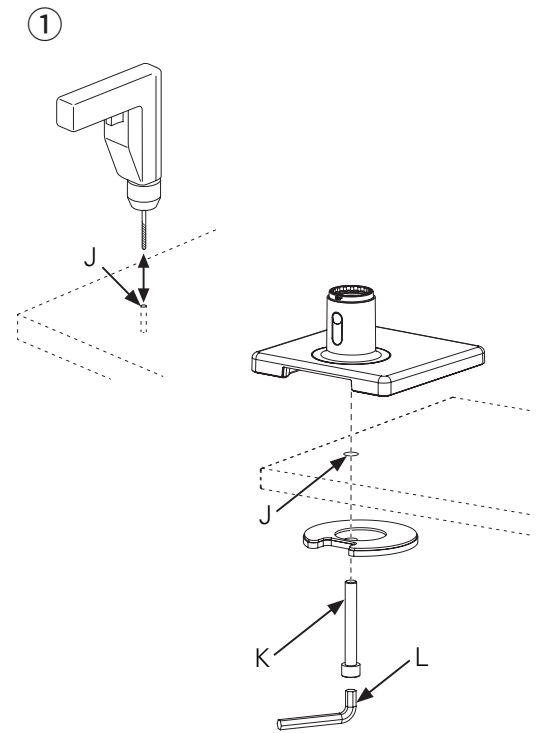

## Smart Stop Adjustment

In each arm connection, there is an adjustable Smart Stop Ring which can be positioned to limit the arm's range of motion. Depending on the orientation of the ring the arms can be set to rotate either 90°, 180°, or 360°. The marked angle will be in the center of the range of motion.

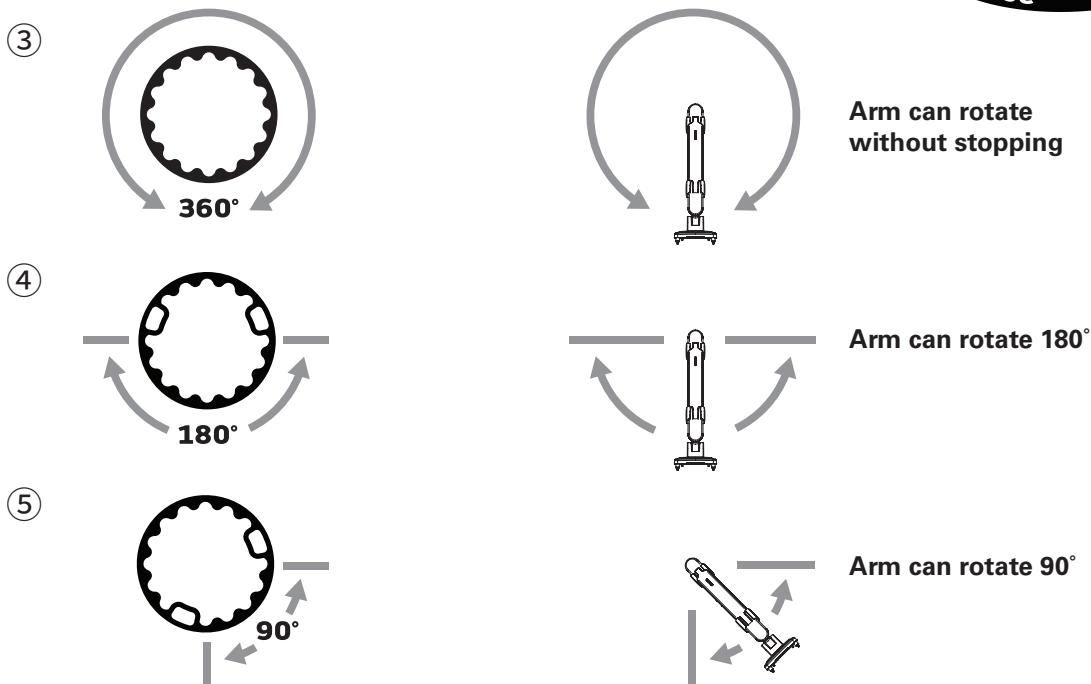

## Attach Arm To Base Stem

**NOTE:** Before adding each link, adjust the smart stop (A) according to step 2. The links should be positioned so that the monitors do not extend beyond the desk surface.

- 1 Insert the angled link into the mount until release button locks in place.
- 2 Insert the dynamic link into the angled link until the release button locks in place.
- 3 To remove links, press the release button (B) and lift upward near the joint.

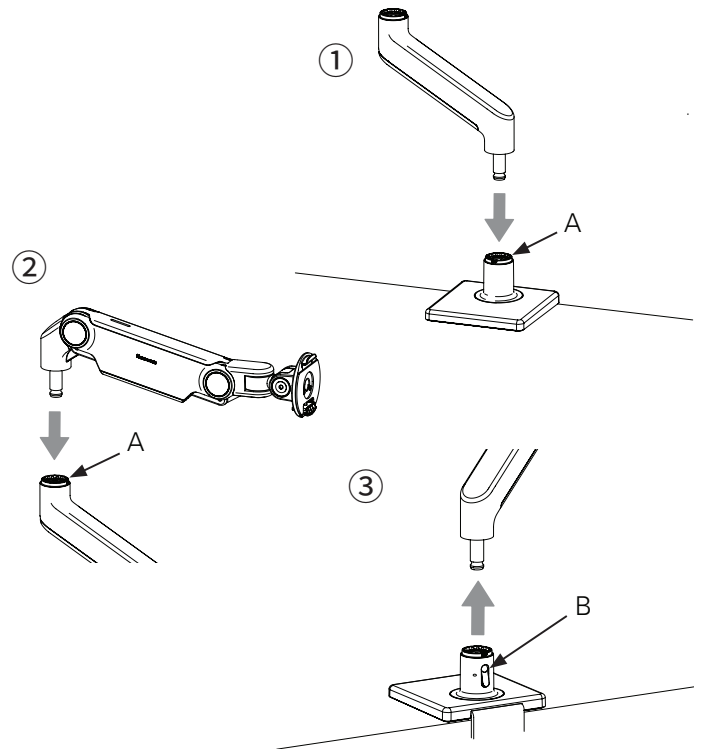

## Attach Crossbar To Arm (Dual-Monitor Application Only)

If using dual monitors, attach the crossbar according to the following steps. If using triple monitors, use the instructions included with the triple crossbar. If using a single monitor, continue to Step 5.

- 1 Attach crossbar (A) to crossbar link (B) using crossbar link screws (C). Tighten with 4mm hex key until secure.
- 2 (Optional) Attach handle (D) to crossbar by using included screws (E). Adjust the handle to desired height. Tighten with 4mm hex key until secure.

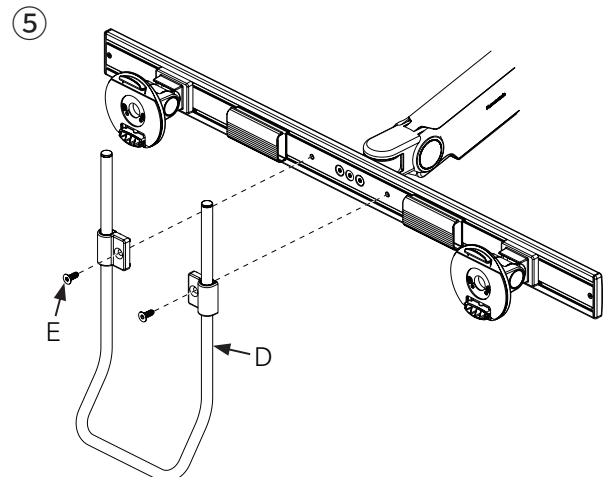
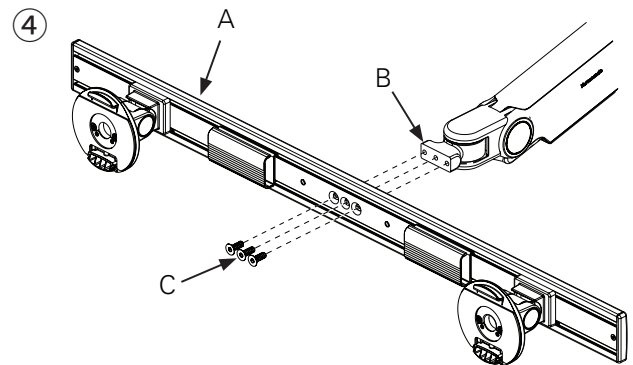

**WARNING:** Risk of Injury- Do not allow crossbars to be positioned so that the monitors extend beyond the work surface which the mount is installed to at all times.

## Attach Vesa Bracket To Monitor

- 1 Separate the VESA cover from the VESA bracket.
- 2 Position the VESA Bracket over the mounting holes on the back of monitor with the D-shaped cutouts in a vertical orientation. Attach using the 4 VESA screws provided.
- 3 Snap the VESA cover back in place.

The VESA Bracket features 75mm and 100mm hole patterns.

If you need to offset the Bracket from the monitor use the provided

Extended VESA screws and Plastic Spacers. You may also use the screws that came with your monitor.

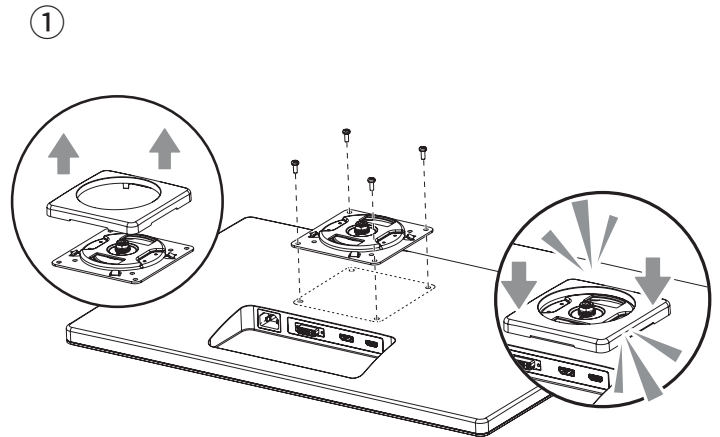

---

## Attach Monitor To Arm

- 1 Hold the monitor angled back and lower it onto the arm. Fit the hook at the top of the arm into the corresponding cutout in the VESA Bracket.
- 2 Tilt the monitor back upright until the Quick Release Tab (B) on the arm snaps into position.
- 3 To remove the monitor, lift the Quick Release Tab and pull the bottom of the monitor away from the arm, then lift free of the hook.

**Large/curved monitors** require adjusting the tension screw (A) Clockwise until the monitor holds in position. (approx. 35 in-lbs.)

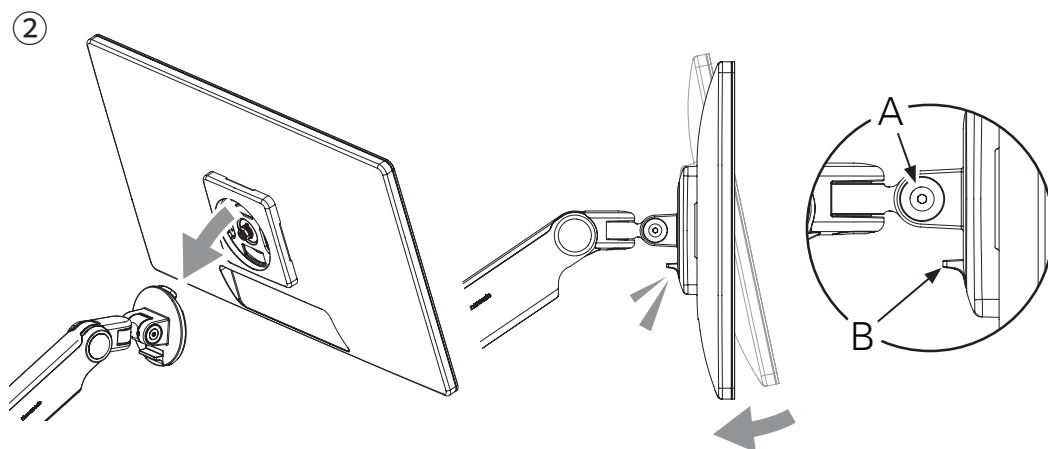

## Leveling The Monitors (Dual-Monitor Application Only)

After the monitors are installed on the crossbar, there may be a small height difference between them. To align the monitors, use the adjustment screw located on top of the monitor tilt.

- 1 To raise a monitor, turn the screw clockwise. To lower, turn counter clockwise.
- 2 (Optional) Attach handle (D) to crossbar by using included screws (E). Adjust the handle to desired height. Tighten with 4mm hex key until secure.

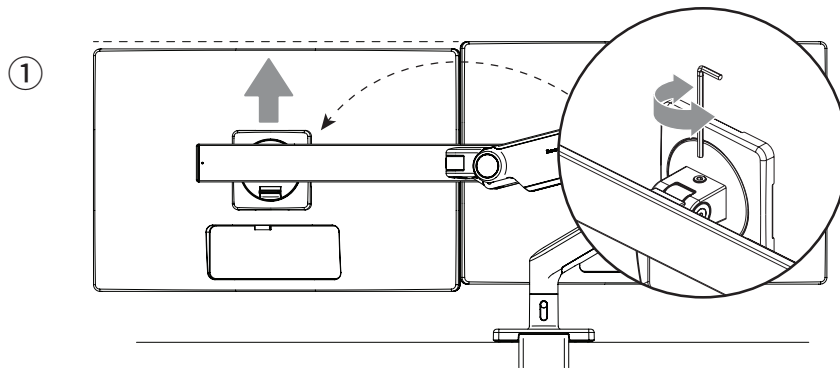

## Weight Adjustment

Your monitor should move up and down easily and stay in place once adjusted. If it is difficult to adjust or moves without assistance, it is not properly counterbalanced.

**M10 Arm - Total Weight Range: 20-48 lbs. (9-21.7 kg)**  
**Single Monitor - Max weight: 48 lbs. (21.7 kg)**  
**Dual Crossbar - Max weight per monitor: 12.5 lbs. (5.6 kg)**  
**Triple Crossbar - Max weight per monitor: 10 lbs. (4.5 kg)**

- 1 To access the Adjustment Screw (D), use your finger to pry open the Cover (C) on the Upper Arm Link (B).
- 2 Using the 5mm Hex Key turn the Adjustment Screw (D) clockwise to **increase** the load tension, and counter-clockwise to **decrease** the load tension. Turn the Adjustment Screw (D) until the Monitor is properly balanced.
- 3 Move the monitor around to ensure that the motion is smooth and the arm functions as intended and holds the monitor in place.
- 4 Reposition the Cover (C) and press until it snaps into place.

**CAUTION:** Do not over tighten the screws as it can damage the screw head or threads.

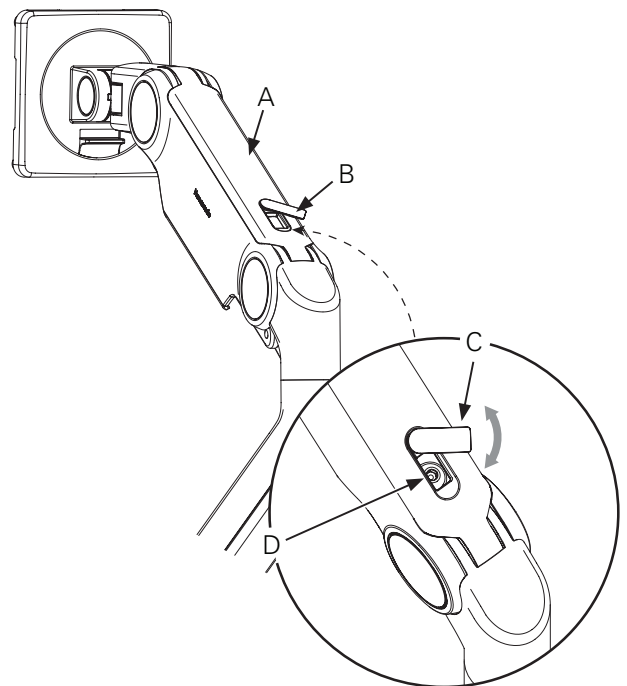

## Cable Management

1 If using multiple monitors, first route the cables through the plastic cable clips on the front of the crossbar. If using a single monitor, skip to step 2.

2 Route power and monitor cables through the flexible cable clips on the M10's upper link (B).

**NOTE:** Leave enough slack in the cables to allow arms to rotate without difficulty.

3 Slide the plastic cover (C) on the lower link upward to remove.

4 Using the two cutouts (D) as guides, run the cables over the lower link cover.

5 Lift the cover and cables up to the lower link, making sure that the cover sits flush with the surface of the arm.

6 Slide the cover down the arm to lock in place, then gently pull the cables through the arm to remove excess slack.

**CAUTION:** Don't insert extension cords. Don't insert any cord connecting one workstation to another.

