

Guub Lock - Public.

User Guide

① Open

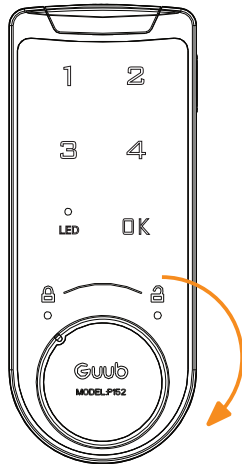

① ② ③ ① ② ③
Default Code

② Set Code & Lock



② ③ ④ ② ③ ④
New Code

③ Unlock

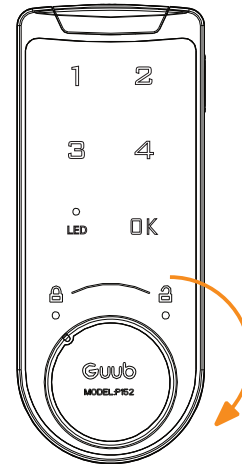

② ③ ④ ② ③ ④
New Code

Public Mode is suitable for use when a locker will be used only temporarily by a user, setting their own combination to lock the locker for the day, and leaving the lock in the Open position once finished.

The factory default access combination is set to '123123'.

Using the Lock

1. To set a combination for the day, first enter '123123' and turn the knob to the Open position. The locker will be unlocked, and items can be placed inside. You can skip straight to setting your own combination if the lock is already in the Open position.
2. With the lock in the Open position the access code can be reset to a new six-digit combination, for example '234234'.

Close the door before turning the knob to the Locked position.

How to Unlock

3. Enter the access code that was set earlier. Turn the knob to the Open position.

The locker will now be unlocked and the access code restored to default. Leave the lock in the Open position for the next user.

AWM

**AWM
AMARO**

Guub Lock - Private.

User Guide

① Open

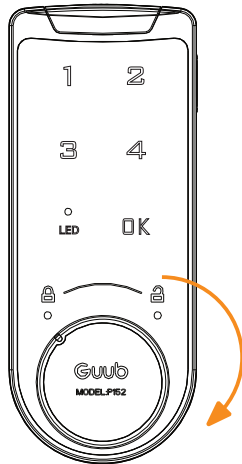

①②③①②③ OK
Default Code

② Set New Code



①②③①②③ OK OK
Default/Current Code
②③④②③④ OK
New Code

③ Unlock

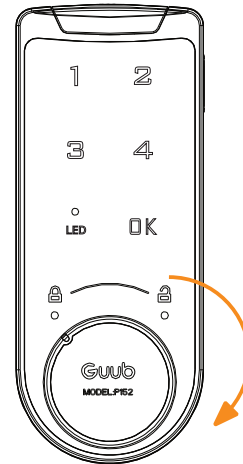

②③④②③④ OK
New Code

Private Mode is suitable for use when a locker will be allocated permanently to an individual.

The factory default access code is set to '123123'.

Using the Lock

1. Enter '123123' and press the 'OK' button. The lock will make a long beep sound.

Turn the knob to the Open position to unlock and open the door.

To lock the door, first close it before turning the knob to the Locked position.

How to Set a New Code

2. Enter the current access code for that lock, the factory default is '123123', followed by 'OK' + 'OK'. The lock will make a long beep noise.

Enter a new access code up to eight digits long, followed by 'OK'. For example '321321' + 'OK'. The lock will make a long beep.

3. The lock can be now used as before with this new access code.

Guub Lock.

Troubleshooting Guide

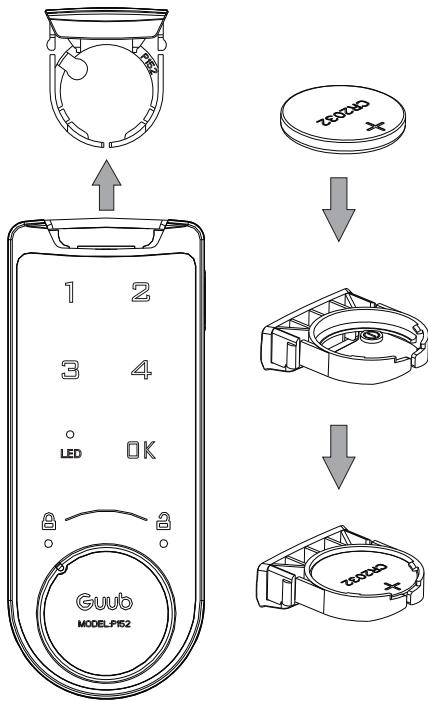

Replacing Flat Battery

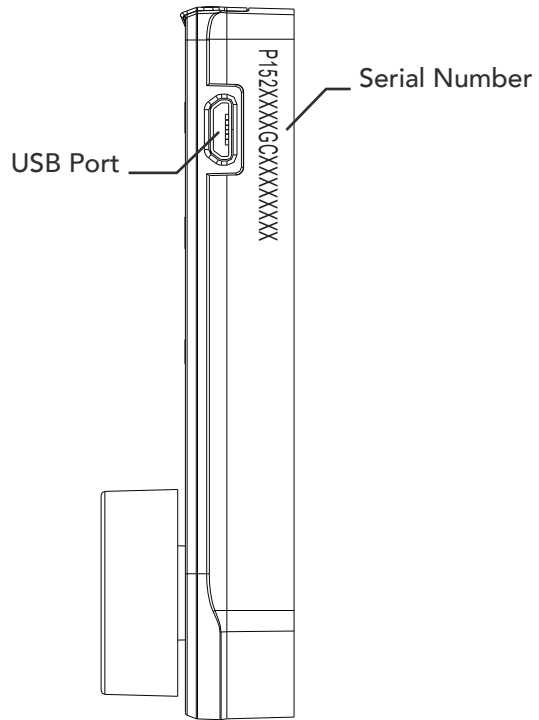

Emergency Unlocking

The lock beeps twice after entering a code and will not unlock	Incorrect Code	Attempt again
The lock produces a long beep after entering the correct code, followed by three short beeps	Low Battery	Remove battery cover at the top of the lock, and replace the old with a new CR2032 battery.
The lock produced a long beep after entering the correct code but will not unlock	The knob is not in the Lock position	Turn the knob back to the Lock position and try again
No sound when keying in numbers but lock can be opened	Lock buzzer is broken	Requires replacement by AWM

In the event that the access code has been lost, there are two methods to open the lock.

Serial Number

Each lock will have a unique serial number printed on the right hand side of the lock. Contact AWM and state the serial number. They will then be able to provide an override code to restore the lock to factory defaults.

USB Key

A red USB key will be provided during handover. Insert this key into the USB port on the side of the lock and press 'OK'. The lock will make a long beep followed by three shorts beeps. The lock will unlock and be restored to factory defaults.